

良機

1962創業

Cooling Tower

Series

LCC-S

LIANG CHI INDUSTRY CO., LTD.

多功能冷却塔性能測試場
COOLING TOWER TEST LABORATORY PER C.T.I. 美國冷却塔協會基準

Liang Chi Series LCC-S have been designed for closed circuit cross flow type cooling towers with Low Noise Motor and Fan. The compact design is suitable for Equipment Cooling, Industrial Process Cooling and Air Conditioning.



Thermal Performance certified by the Cooling Technology Institute (CTI) in accordance with CTI STD-201

Characteristics

Designed to International Standards:

Series LCC-S cooling towers have been meticulously designed in accordance with international standards, featuring a lightweight structure that facilitates easy transportation, lifting, and on-site installation.

Low Noise Level & Simple Maintenance:

Incorporating high efficiency V-belt reducers paired with low-noise axial flow fans, the Series LCC-S cooling towers operate silently and are easily maintained.

Lightweight Build, Space Efficiency, and Multi-Cell Installation:

In contrast to other closed circuit cooling tower variants, the LCC-S series features a lighter operational weight and occupies less installation space. Additionally, its combinative multi-cell configuration suits large cooling demands and provides room for future expansion.

Innovative Distribution System for Efficient Heat Exchange:

Employing a gravitational distribution system characterized by low pressure and gradual water flow, these cooling towers extend cooling duration and enhance overall efficiency.

Optimized Heat Exchange Performance:

The unique design of vacuum-formed, round-chorded fillings with ripple surfaces ensures uniform water distribution, prolonged water droplet contact, and prevents deposits and scales from forming.

Minimized Electrical Power Consumption:

The LCC-S cooling towers utilize a highly efficient hydrodynamic "venturi-tube" fan stack coupled with low-resistance fillings, promoting excellent ventilation and reducing fan motor power consumption, thereby conserving electrical energy.

Longevity and Durability:

LCC-S tower components are constructed from weatherproof, anti-corrosive materials. The casing, fan stack, basin, access door are made of anti-ultraviolet F.R.P (Fiberglass Reinforced Plastic) and the filling, inlet louvers are made of anti-ultraviolet P.V.C boosting resistance to UV radiation and duration. Additionally, the supporting rack is made of lightweight galvanized steel, enhancing the overall service life of the cooling tower.

Convenient Inner Piping Arrangement & Cost Savings:

The LCC-S design adopts an inner piping arrangement, ensuring that the outer maintenance area remains free of pipes. This enhances ease and safety during tower maintenance while simultaneously reducing the cost associated with outer piping work.

Efficient Heat Exchange Coil Pack:

The heat exchange coil packs are fashioned from corrugated stainless tubes known for their exceptional heat transfer efficiency and anti-corrosion properties. The stainless construction coil pack ensures a corrosion-resistance, leading to an extended service life. Furthermore, the heat exchange coil packs are divided into 4~5 sets per side of the tower, allowing for easy dismantling and flexible operation. In the event of repairs, individual coil packs can be addressed while the remaining packs continue to function seamlessly.

Structure and Standard Materials

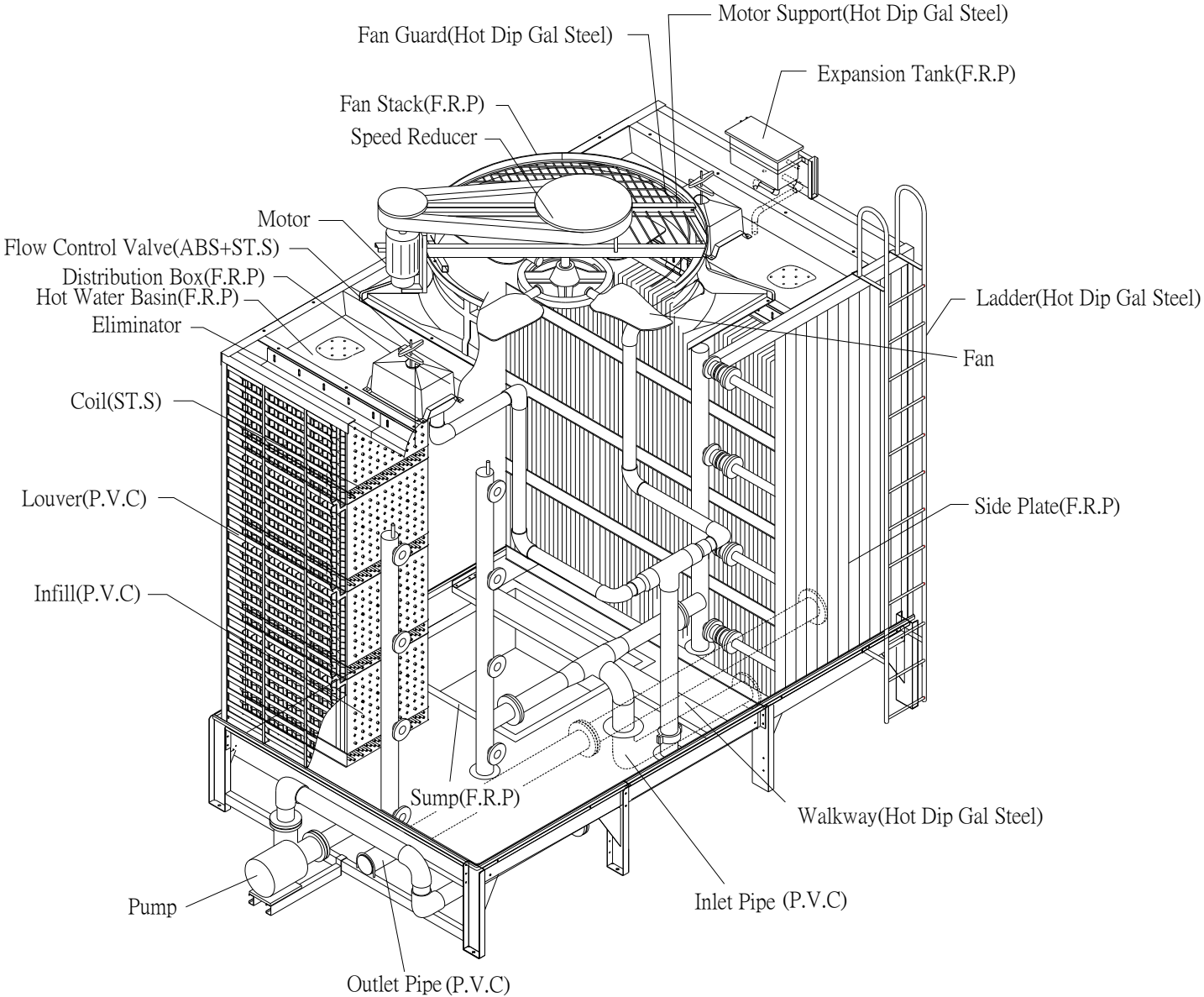

Recommended Concrete Foundations

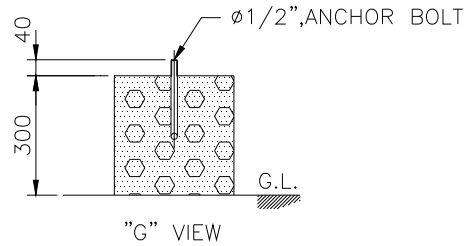
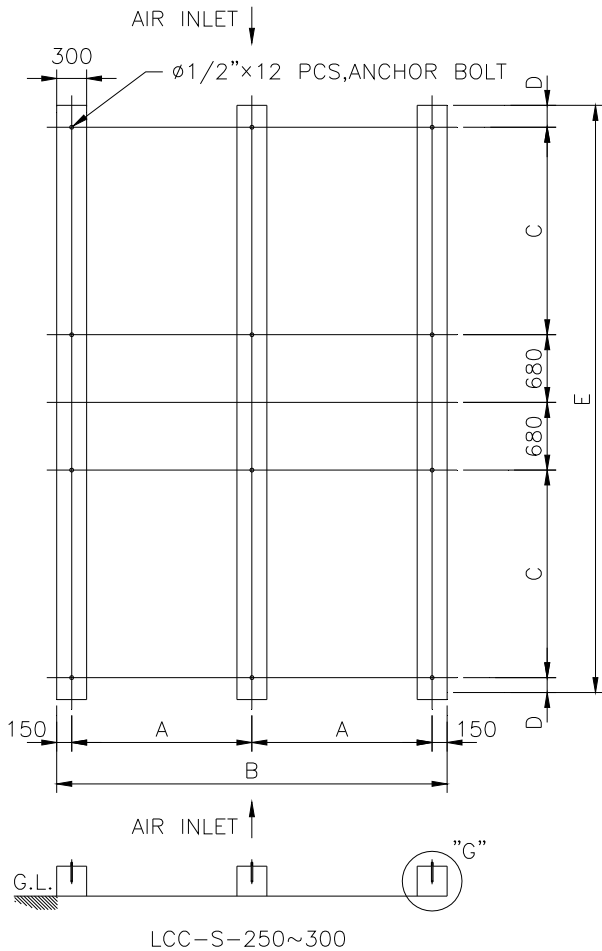
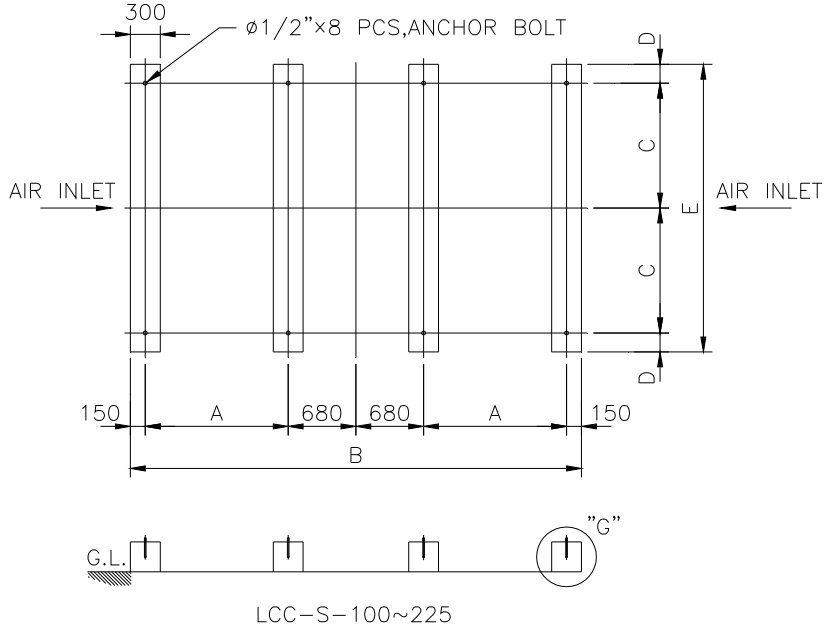
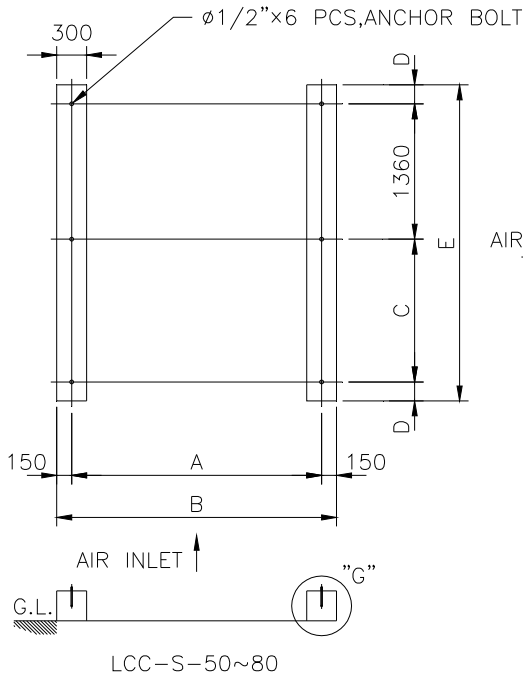

NOTES :

- 1.The anchor bolts are ø1/2" anchor bolts.
- 2.All concrete foundations must be leveled and aligned on the top.
- 3.The concrete foundations as shown are non-isolator type. For isolator type, please contact your local supplier or distributor.
- 4.Multiple cell models of the single cell models are also available but not showed. For more information, please contact your local supplier or distributor.
- 5.All dimensions are in millimeters.

LCC-S ITEMS	50	60	70	80	100	125	150	175	200	225	250	300
A	2210	2210	2510	2810	1335	1335	1485	1485	1685	1685	1810	1810
B	2510	2510	2810	3110	4330	4330	4630	4630	5030	5030	3920	3920
C	1335	1335	1435	1435	1105	1105	1405	1405	1405	1405	2085	2085
D	190	190	190	190	190	190	190	190	220	220	220	220
E	3075	3075	3175	3175	2590	2590	3190	3190	3250	3250	5970	5970

Dimensions and Standard Specifications

LCC-S-50~80

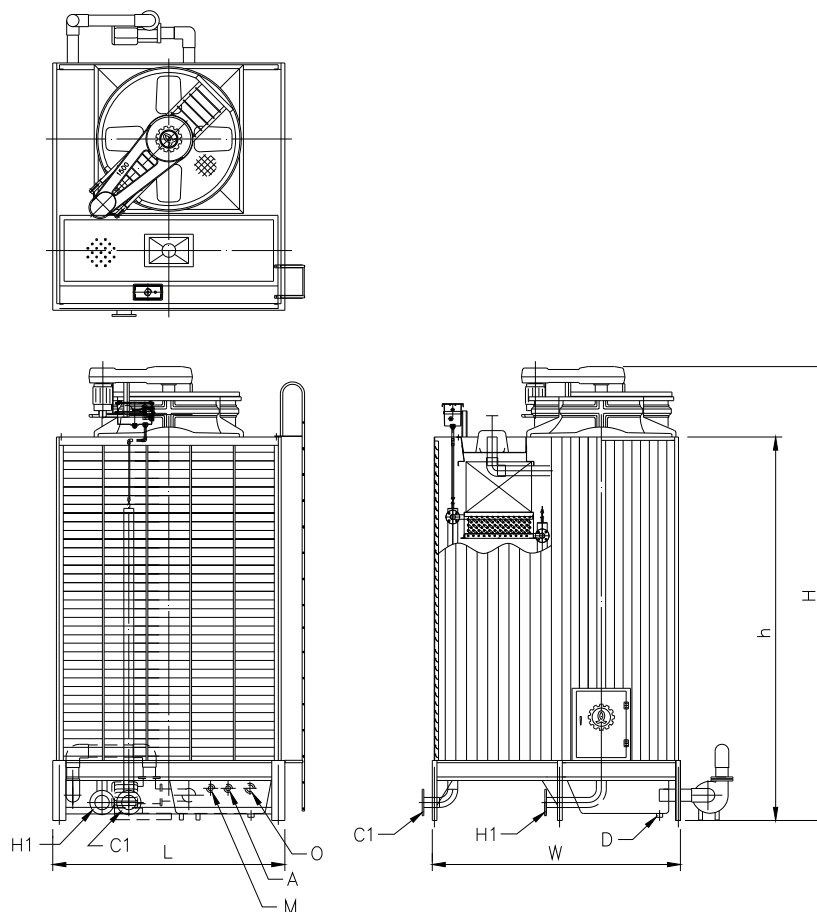

LCC-S-100~175

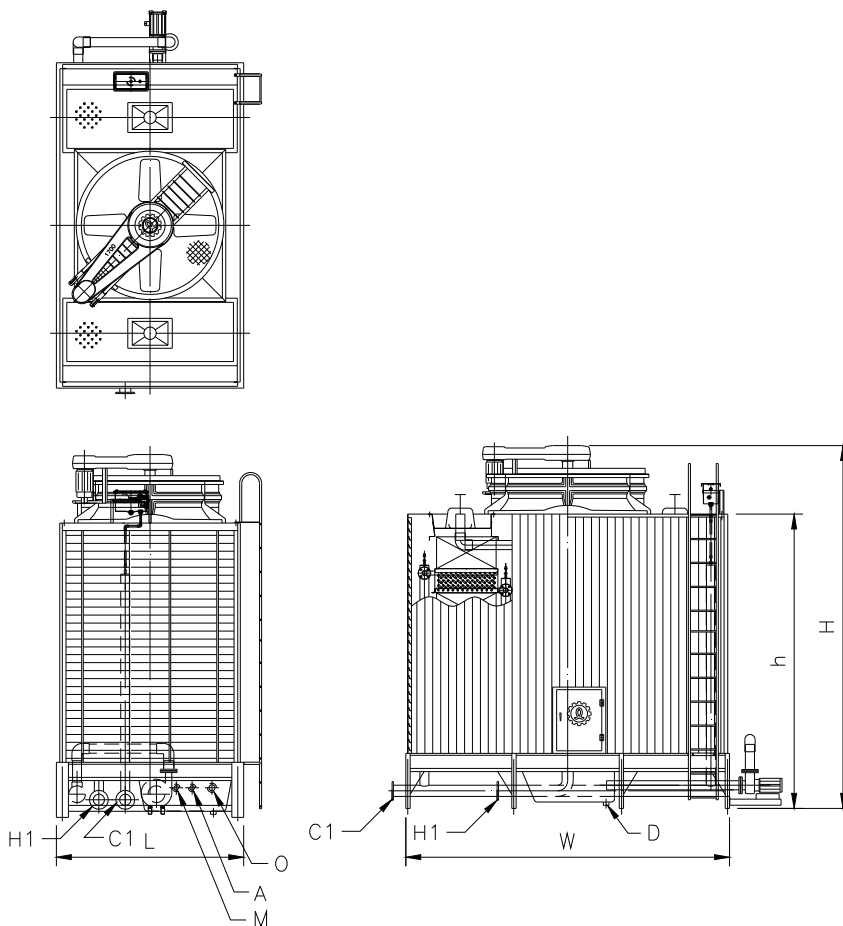

LCC-S-200~225

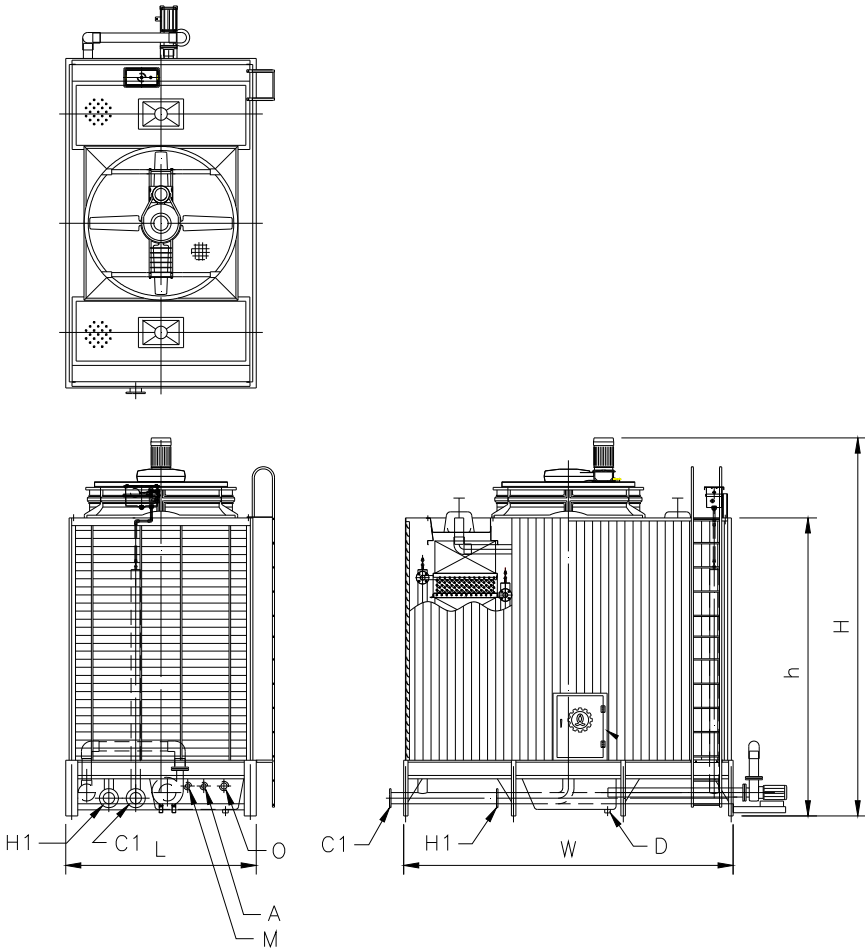

LCC-S-250~300

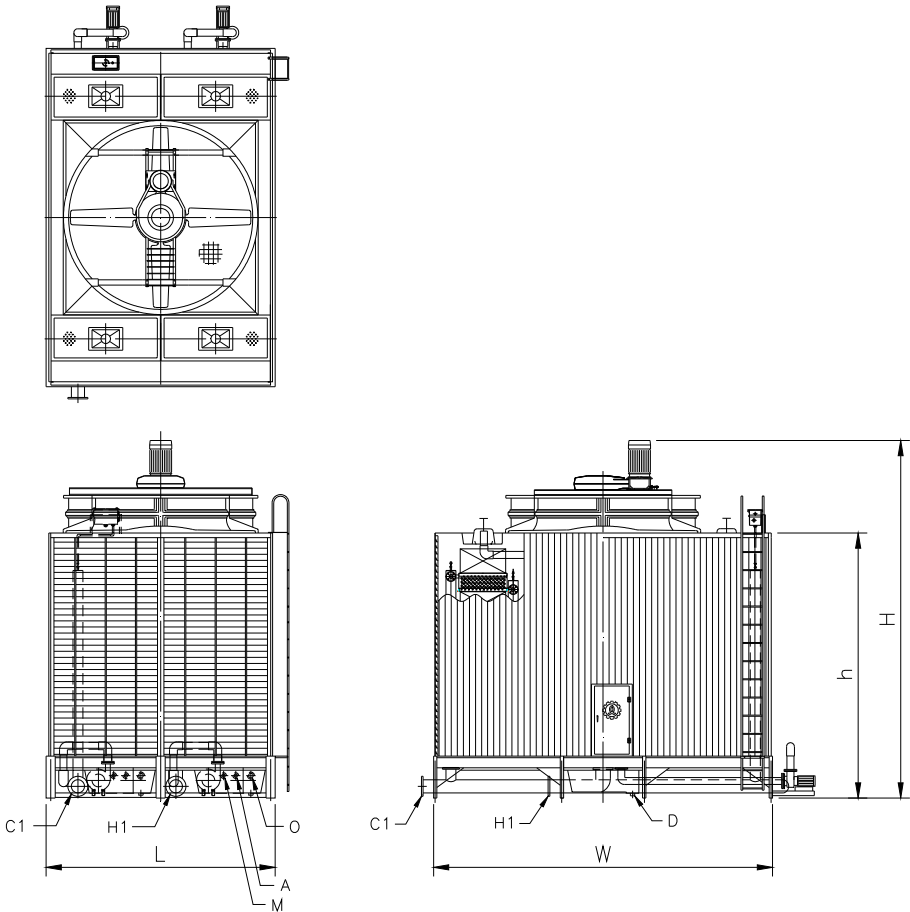

Model Number	Nominal Ton*1	Internal Coil Flow Rate (LPS)	Dimensions				Fan Dia. (mm)	Fan Motor (HP)
			Width(mm)	Length(mm)	Height(mm)			
			W	L	h	H		
LCC-S-								
50	50	10.8	2745	2360	3690	4510	1300	2
60	60	13	2745	2360	4410	5230	1300	2
70	70	15.2	2845	2660	4410	5220	1500	5
80	80	17.3	2845	2960	4410	5220	1500	5
100	100	21.7	4080	2360	3690	4550	1700	7 1/2
125	125	27.1	4080	2360	4410	5270	1700	7 1/2
150	150	32.5	4380	2960	3690	4570	2000	10
175	175	37.9	4380	2960	4410	5290	2000	10
200	200	43.3	4780	2960	4370	5730	2360	15
225	225	48.7	4780	2960	5270	6630	2360	15
250	250	54.2	5580	3770	4370	5895	2970	15
300	300	65	5580	3770	5270	6795	2970	15

Model Number	Connection Sizes						Approximate Weights	
	Inlet	Outlet	Drain	Over Flow	Auto Filler	Quick Filler	Shipping (KG)	Operating (KG)
	(H1)	(C1)	(D)	(O)	(A)	(M)		
LCC-S-								
50	4B(100A)	4B(100A)	2B(50A)	2B(50A)	3/4B(20A)	3/4B(20A)	1150	2950
60	4B(100A)	4B(100A)	2B(50A)	2B(50A)	3/4B(20A)	3/4B(20A)	1330	3420
70	4B(100A)	4B(100A)	2B(50A)	2B(50A)	3/4B(20A)	3/4B(20A)	1680	3890
80	4B(100A)	4B(100A)	2B(50A)	2B(50A)	3/4B(20A)	3/4B(20A)	1970	4350
100	5B(125A)	5B(125A)	2B(50A)	2B(50A)	3/4B(20A)	3/4B(20A)	2000	4400
125	5B(125A)	5B(125A)	2B(50A)	2B(50A)	3/4B(20A)	3/4B(20A)	2320	5100
150	6B(150A)	6B(150A)	2B(50A)	2B(50A)	1B(25A)	1B(25A)	2600	5600
175	6B(150A)	6B(150A)	2B(50A)	2B(50A)	1B(25A)	1B(25A)	3010	6480
200	6B(150A)	6B(150A)	2B(50A)	2B(50A)	1B(25A)	1B(25A)	3680	7490
225	8B(200A)	8B(200A)	2B(50A)	2B(50A)	1 1/2B(40A)	1 1/2B(40A)	4260	8670
250	8B(200A)	8B(200A)	2B(50A)×2	2B(50A)×2	3/4B(20A)×2	3/4B(20A)×2	5810	11480
300	8B(200A)	8B(200A)	2B(50A)×2	2B(50A)×2	1B(25A)×2	1B(25A)×2	6700	13230

Model Number	Circulating Cooling Water Pump				Coil Head (M)
	Motor	Pipe Size	Water Flow	Head	
	(HP)	(inches)	(LPM)	(M)	
50	2	3	625	5.8	4
60	2	3	625	5.8	5
70	2	4	835	5.8	7
80	2	4	835	5.8	9
100	3	4	1300	5.8	4
125	3	4	1300	5.8	6
150	5	5	2003	5.8	8
175	5	5	2003	5.8	11
200	5	5	2003	5.8	9
225	7.5	6	2600	5.8	11
250	3x2	4x2	2600	5.8	14
300	5x2	5x2	4006	5.8	20

1. Nominal Tons is defined as the capacity that can deal with 13 lpm of water per ton, cooled from a 37°C Entering Water Temperature to a 32°C Leaving Water Temperature at a 27°C entering wet bulb temperature.
2. Total pump head required for cooling water circulation pump is the sum of condenser water pressure drop, piping friction loss and tower head.
3. All dimensions are in millimeters. Weights are in kilograms.
4. Multiple cell models of the single cell models above are also available but not listed. For more information, please contact your local supplier or distributor.

STD-201RS Table 3b - SI Units - Cooling Towers (CT)

Condition Reference #	1	2	3	4	5	6	7	8	9	10
Wet Bulb °C	10	10	10	10	10	13	13	13	13	13
Range °C	6	6	6	8	8	6	6	6	8	8
Approach °C	4	6	7	4	7	4	6	7	4	7
Inlet Water Temperature °C	20	22	23	22	25	23	25	26	25	28
Outlet Water Temperature °C	14	16	17	14	17	17	19	20	17	20
	L/S									
LCC-S-50	3.7	5.3	6.2	3	5	4.1	6	7	3.4	5.6
LCC-S-60	4.4	6.3	7.4	3.6	6	5	7.2	8.4	4.1	6.8
LCC-S-70	5.1	7.4	8.6	4.2	6.9	5.8	8.3	9.7	4.8	7.9
LCC-S-80	5.8	8.4	9.8	4.8	7.9	6.6	9.5	11.1	5.4	9
LCC-S-100	7.3	10.6	12.3	6.1	9.9	8.3	12	14	6.9	11.3
LCC-S-125	9.1	13.2	15.4	7.6	12.4	10.3	15	17.4	8.6	14.1
LCC-S-150	11	15.9	18.5	9.1	14.9	12.4	18	20.9	10.3	16.9
LCC-S-175	12.8	18.5	21.6	10.6	17.4	14.5	20.9	24.4	12	19.8
LCC-S-200	14.7	21.2	24.7	12.2	19.9	16.6	24	27.9	13.8	22.6
LCC-S-225	16.4	23.8	27.7	13.6	22.4	18.6	26.9	31.4	15.4	25.4
LCC-S-250	18.3	26.4	30.8	15.2	24.9	20.7	29.9	34.9	17.2	28.2
LCC-S-300	22	31.7	37	18.2	29.9	24.9	35.9	41.9	20.6	33.9

STD-201RS Table 3b - SI Units - Cooling Towers (CT)

Condition Reference #	11	12	13	14	15	16	17	18	19	20
Wet Bulb °C	16	16	16	16	16	18	18	18	18	18
Range °C	6	6	6	8	8	6	6	6	8	8
Approach °C	4	6	7	4	7	4	6	7	4	7
Inlet Water Temperature °C	26	28	29	28	31	28	30	31	30	33
Outlet Water Temperature °C	20	22	23	20	23	22	24	25	22	25
	L/S									
LCC-S-50	4.7	6.8	7.9	3.9	6.4	5.1	7.4	8.7	4.3	7
LCC-S-60	5.6	8.2	9.5	4.7	7.7	6.2	8.9	10.4	5.1	8.4
LCC-S-70	6.5	9.5	11.1	5.4	9	7.1	10.4	12.1	5.9	9.8
LCC-S-80	7.5	10.9	12.7	6.2	10.3	8.2	11.9	13.9	6.8	11.2
LCC-S-100	9.4	13.6	15.9	7.8	12.9	10.3	14.9	17.4	8.5	14.1
LCC-S-125	11.8	17	19.9	9.8	16.1	12.8	18.6	21.7	10.7	17.6
LCC-S-150	14.1	20.4	23.8	11.7	19.3	15.4	22.3	26.1	12.8	21.1
LCC-S-175	16.5	23.8	27.8	13.7	22.5	18	26	30.4	15	24.6
LCC-S-200	18.9	27.3	31.8	15.7	25.8	20.6	29.8	34.8	17.2	28.2
LCC-S-225	21.1	30.6	35.7	17.6	28.9	23.1	33.5	39.1	19.2	31.7
LCC-S-250	23.6	34.1	39.7	19.6	32.2	25.7	37.2	43.4	21.4	35.2
LCC-S-300	28.3	40.9	47.7	23.5	38.6	30.9	44.7	52.1	25.7	42.3

STD-201RS Table 3b - SI Units - Cooling Towers (CT)

Condition Reference #	21	22	23	24	25	26	27	28	29	30
Wet Bulb °C	21	21	21	21	21	24	24	24	24	24
Range °C	6	6	6	8	8	6	6	6	8	8
Approach °C	4	6	7	4	7	4	6	7	4	7
Inlet Water Temperature °C	31	33	34	33	36	34	36	37	36	39
Outlet Water Temperature °C	25	27	28	25	28	28	30	31	28	31
	L/S									
LCC-S-50	5.9	8.5	10	4.9	8.1	6.8	9.8	11.4	5.6	9.3
LCC-S-60	7.1	10.2	11.9	5.9	9.7	8.1	11.8	13.7	6.8	11.2
LCC-S-70	8.2	11.9	13.9	6.8	11.3	9.4	13.7	16	7.8	13
LCC-S-80	9.4	13.6	15.9	7.8	12.9	10.8	15.7	18.3	9	14.8
LCC-S-100	11.8	17	19.9	9.8	16.2	13.5	19.6	22.9	11.3	18.6
LCC-S-125	14.7	21.3	24.9	12.3	20.2	16.9	24.5	28.6	14.1	23.2
LCC-S-150	17.7	25.6	29.9	14.7	24.2	20.3	29.4	34.3	16.9	27.9
LCC-S-175	20.6	29.8	34.8	17.2	28.3	23.7	34.3	40	19.8	32.6
LCC-S-200	23.6	34.1	39.8	19.7	32.4	27.1	39.2	45.8	22.6	37.2
LCC-S-225	26.5	38.3	44.8	22	36.3	30.4	44.1	51.5	25.3	41.8
LCC-S-250	29.5	42.6	49.8	24.5	40.4	33.9	49	57.2	28.2	46.5
LCC-S-300	35.4	51.2	59.7	29.4	48.5	40.6	58.8	68.6	33.9	55.8

STD-201RS Table 3b - SI Units - Cooling Towers (CT)

Condition Reference #	31	32	33	34	35	36	37	38	39	40
Wet Bulb °C	27	27	27	27	27	29	29	29	29	29
Range °C	6	6	6	8	8	6	6	6	8	8
Approach °C	4	6	7	4	7	4	6	7	4	7
Inlet Water Temperature °C	37	39	40	39	42	39	41	42	41	44
Outlet Water Temperature °C	31	33	34	31	34	33	35	36	33	36
	L/S									
LCC-S-50	7.8	11.3	13.2	6.5	10.7	8.6	12.4	14.5	7.2	11.8
LCC-S-60	9.3	13.6	15.8	7.8	12.9	10.3	14.9	17.4	8.6	14.2
LCC-S-70	10.9	15.8	18.5	9.1	15	12	17.4	20.4	10	16.5
LCC-S-80	12.4	18.1	21.1	10.3	17.1	13.7	19.9	23.3	11.4	18.9
LCC-S-100	15.6	22.6	26.4	13	21.5	17.2	24.9	29	14.3	23.6
LCC-S-125	19.5	28.2	33	16.3	26.8	21.5	31.1	36.3	17.9	29.5
LCC-S-150	23.4	33.9	39.6	19.5	32.2	25.8	37.3	43.5	21.5	35.4
LCC-S-175	27.3	39.5	46.1	22.8	37.5	30	43.5	50.8	25.1	41.3
LCC-S-200	31.2	45.2	52.7	26.1	42.9	34.4	49.7	58	28.7	47.3
LCC-S-225	35.1	50.8	59.4	29.2	48.3	38.6	55.9	65.3	32.2	53.2
LCC-S-250	39	56.5	65.9	32.6	53.6	42.9	62.1	72.5	35.9	59.1
LCC-S-300	46.8	67.7	79.1	39.1	64.4	51.5	74.5	87	43	70.9

STD-201RS Table 3b - SI Units - Cooling Towers (CT)

Condition Reference #	41	42	43	44	45		46	47	48	49
Wet Bulb °C	32.2	32.2	32.2	32.2	32.2		21	25.56	27	28
Range °C	6	6	6	8	8		5	5.56	5	5
Approach °C	4	6	7	4	7		6	3.89	5	4
Inlet Water Temperature °C	42.2	44.2	45.2	44.2	47.2		32	35.00	37	37
Outlet Water Temperature °C	36.2	38.2	39.2	36.2	39.2		27	29.44	32	32
	L/S									
LCC-S-50	10	14.5	16.9	8.4	13.8		9.8	7.5	10.8	9.3
LCC-S-60	12	17.4	20.3	10	16.6		11.7	8.9	13	11.1
LCC-S-70	14	20.3	23.8	11.7	19.3		13.7	10.4	15.2	12.9
LCC-S-80	16	23.3	27.2	13.3	22.1		15.7	11.9	17.3	14.8
LCC-S-100	20.1	29	33.9	16.8	27.6		19.6	14.9	21.7	18.5
LCC-S-125	25.1	36.3	42.3	20.9	34.5		24.5	18.7	27.1	23.2
LCC-S-150	30.1	43.5	50.8	25.2	41.4		29.4	22.4	32.5	27.8
LCC-S-175	35.1	50.8	59.2	29.3	48.3		34.3	26.1	37.9	32.4
LCC-S-200	40.1	58	67.6	33.6	55.2		39.2	29.9	43.3	37.1
LCC-S-225	45.1	65.3	76.2	37.7	62.1		44	33.6	48.7	41.7
LCC-S-250	50.1	72.5	84.6	41.9	69		48.9	37.4	54.2	46.3
LCC-S-300	60.2	87	101.5	50.3	82.8		58.7	44.8	65	55.6



• Office : No.1, Sec.3, Nanking E. Rd., Taipei, Taiwan, Rep. of China.

Tel : 886-2-2506-3588~98 Fax : 886-2-2508-4134

• Factory : No.291, Sec.2, Hae-sun Rd., Hae-Hwe Village, Taoyuan, Taiwan, R.O.C.

Tel : 886-3-354-1201~10 Fax : 886-3-354-1426

• [Http://www.liangchi.com](http://www.liangchi.com) E-mail:intl-trade@liangchi.com.tw

